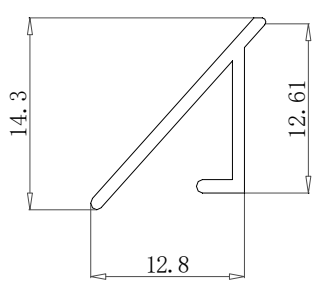
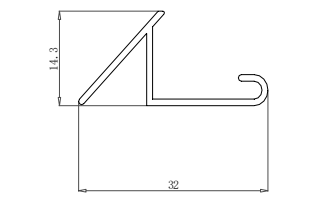
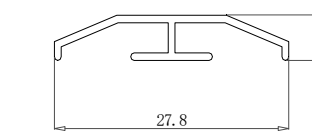
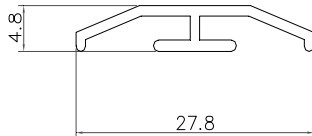
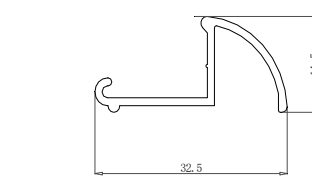
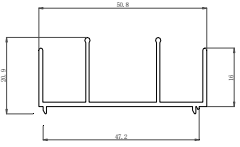
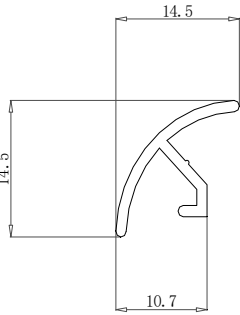
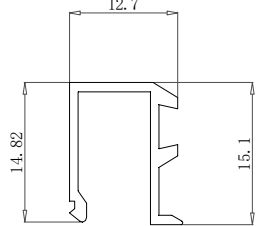
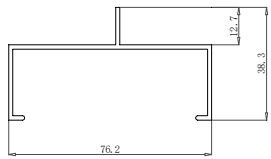
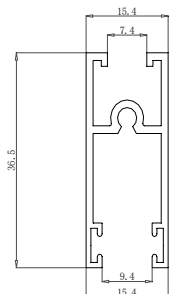
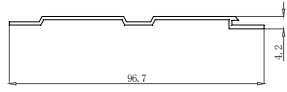
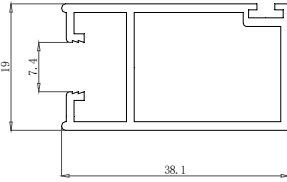
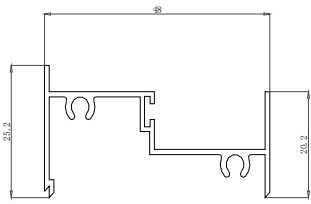
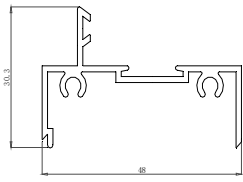
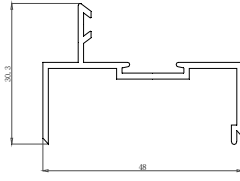
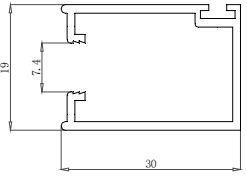
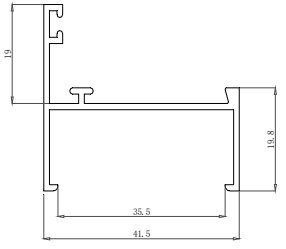
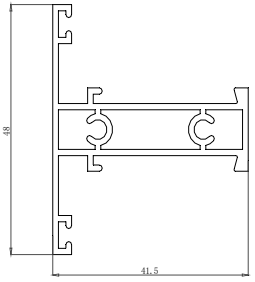
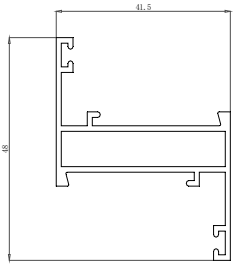
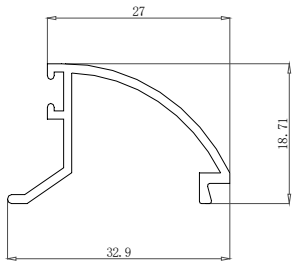

NO.	Item		Diagram
1	Draw No.	EGDE01	
	Thickness (mm)	1	
	Theory Weight (kg/m)	0.09	
	Exposed Surface (m <sup>2</sup> /m)	0.0378	
2	Draw No.	EGDE02	
	Thickness (mm)	1	
	Theory Weight (kg/m)	0.154	
	Exposed Surface (m <sup>2</sup> /m)	0.0701	
3	Draw No.	EGDE03	
	Thickness (mm)	0.8	
	Theory Weight (kg/m)	0.096	
	Exposed Surface (m <sup>2</sup> /m)	0.0367	
4	Draw No.	EGDE03A	
	Thickness (mm)	1.1	
	Theory Weight (kg/m)	0.13	
	Exposed Surface (m <sup>2</sup> /m)	0.0521	
5	Draw No.	EGDE04	
	Thickness (mm)	1.2	
	Theory Weight (kg/m)	0.192	
	Exposed Surface (m <sup>2</sup> /m)	0.0711	

NO.	Item		Diagram
6	Draw No.	EGDE05	
	Thickness (mm)	1.2	
	Theory Weight (kg/m)	0.371	
	Exposed Surface (m <sup>2</sup> /m)	0.1824	
7	Draw No.	EGDE06	
	Thickness (mm)	1.2	
	Theory Weight (kg/m)	0.109	
	Exposed Surface (m <sup>2</sup> /m)	0.0254	
8	Draw No.	EGDE07	
	Thickness (mm)	1	
	Theory Weight (kg/m)	0.14	
	Exposed Surface (m <sup>2</sup> /m)	0.0445	
9	Draw No.	EGDE08	
	Thickness (mm)	1.5	
	Theory Weight (kg/m)	0.595	
	Exposed Surface (m <sup>2</sup> /m)	0.1528	
10	Draw No.	EGDE09	
	Thickness (mm)	1.3	
	Theory Weight (kg/m)	0.373	
	Exposed Surface (m <sup>2</sup> /m)	0.087	

Note: In order to avoid the loss caused by mistakes, please communicate and consult with the Technical Department before choosing. The right of final interpretation belongs to the Technical Department.

NO.	Item		Diagram
11	Draw No.	EGDE10	
	Thickness (mm)	1.1	
	Theory Weight (kg/m)	0.321	
	Exposed Surface (m <sup>2</sup> /m)	0.2123	
12	Draw No.	EGDE11	
	Thickness (mm)	1.3	
	Theory Weight (kg/m)	0.436	
	Exposed Surface (m <sup>2</sup> /m)	0.1177	
13	Draw No.	EGDE12	
	Thickness (mm)	1	
	Theory Weight (kg/m)	0.356	
	Exposed Surface (m <sup>2</sup> /m)	0.1295	
14	Draw No.	EGDE13	
	Thickness (mm)	1.3	
	Theory Weight (kg/m)	0.468	
	Exposed Surface (m <sup>2</sup> /m)	0.1321	
15	Draw No.	EGDE14	
	Thickness (mm)	1.3	
	Theory Weight (kg/m)	0.376	
	Exposed Surface (m <sup>2</sup> /m)	0.1321	

NO.	Item		Diagram
16	Draw No.	EGDE15	
	Thickness (mm)	1.3	
	Theory Weight (kg/m)	0.321	
	Exposed Surface (m <sup>2</sup> /m)	0.1019	
17	Draw No.	EGDE18	
	Thickness (mm)	1.2	
	Theory Weight (kg/m)	0.379	
	Exposed Surface (m <sup>2</sup> /m)	0.1476	
18	Draw No.	EGDE19	
	Thickness (mm)	1.2	
	Theory Weight (kg/m)	0.664	
	Exposed Surface (m <sup>2</sup> /m)	0.2415	
19	Draw No.	EGDE20	
	Thickness (mm)	1.2	
	Theory Weight (kg/m)	0.571	
	Exposed Surface (m <sup>2</sup> /m)	0.2415	
20	Draw No.	EGDE21	
	Thickness (mm)	1.2	
	Theory Weight (kg/m)	0.218	
	Exposed Surface (m <sup>2</sup> /m)	0.0449	

Note: In order to avoid the loss caused by mistakes, please communicate and consult with the Technical Department before choosing. The right of final interpretation belongs to the Technical Department.

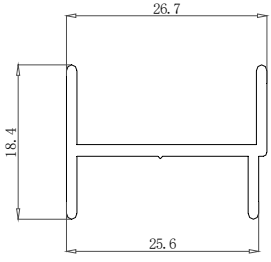
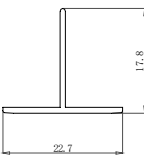
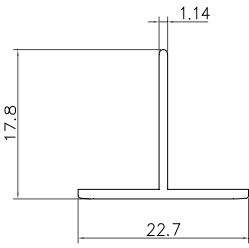
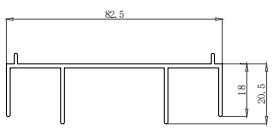
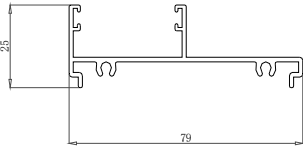
NO.	Item		Diagram
21	Draw No.	EGDE23	
	Thickness (mm)	1.4	
	Theory Weight (kg/m)	0.229	
	Exposed Surface (m <sup>2</sup> /m)	0.1219	
22	Draw No.	EGDE24	
	Thickness (mm)	1	
	Theory Weight (kg/m)	0.107	
	Exposed Surface (m <sup>2</sup> /m)	0.0801	
23	Draw No.	EGDE24B	
	Thickness (mm)	1.14	
	Theory Weight (kg/m)	0.121	
	Exposed Surface (m <sup>2</sup> /m)	0.0801	
24	Draw No.	EGDE32	
	Thickness (mm)	1.4	
	Theory Weight (kg/m)	0.608	
	Exposed Surface (m <sup>2</sup> /m)	0.2422	
25	Draw No.	EGDE33	
	Thickness (mm)	1.4	
	Theory Weight (kg/m)	0.619	
	Exposed Surface (m <sup>2</sup> /m)	0.1939	

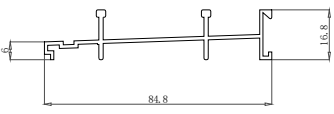
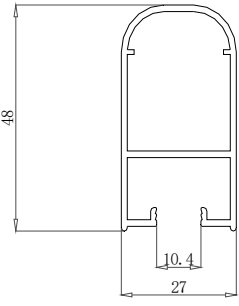
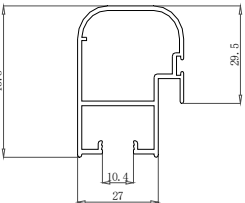
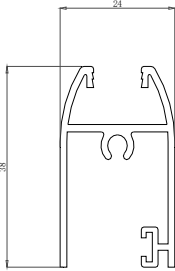
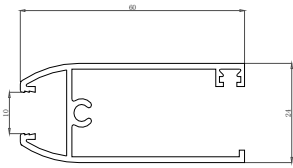
NO.	Item		Diagram
26	Draw No.	EGDE34	
	Thickness (mm)	1.2	
	Theory Weight (kg/m)	0.546	
	Exposed Surface (m <sup>2</sup> /m)	0.1823	
27	Draw No.	EGDE35	
	Thickness (mm)	1.4	
	Theory Weight (kg/m)	0.5967	
	Exposed Surface (m <sup>2</sup> /m)	0.1322	
28	Draw No.	EGDE36	
	Thickness (mm)	1.4	
	Theory Weight (kg/m)	0.673	
	Exposed Surface (m <sup>2</sup> /m)	0.1678	
29	Draw No.	EGDE37	
	Thickness (mm)	1.4	
	Theory Weight (kg/m)	0.501	
	Exposed Surface (m <sup>2</sup> /m)	0.0982	
30	Draw No.	EGDE38	
	Thickness (mm)	1.4	
	Theory Weight (kg/m)	0.659	
	Exposed Surface (m <sup>2</sup> /m)	0.1358	

Note: In order to avoid the loss caused by mistakes, please communicate and consult with the Technical Department before choosing. The right of final interpretation belongs to the Technical Department.

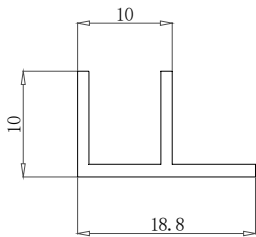
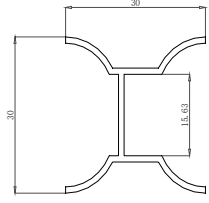
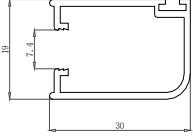
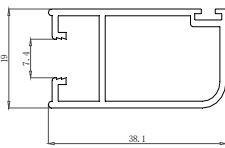
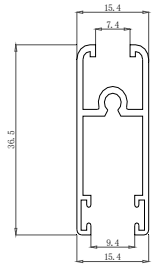
NO.	Item		Diagram
31	Draw No.	EGDE50	
	Thickness (mm)	1.2	
	Theory Weight (kg/m)	0.119	
	Exposed Surface (m <sup>2</sup> /m)	0.03	
32	Draw No.	EGDE52	
	Thickness (mm)	1.2	
	Theory Weight (kg/m)	0.277	
	Exposed Surface (m <sup>2</sup> /m)	0.1721	
33	Draw No.	EGDE53	
	Thickness (mm)	1.3	
	Theory Weight (kg/m)	0.314	
	Exposed Surface (m <sup>2</sup> /m)	0.0997	
34	Draw No.	EGDE54	
	Thickness (mm)	1.3	
	Theory Weight (kg/m)	0.429	
	Exposed Surface (m <sup>2</sup> /m)	0.1155	
35	Draw No.	EGDE55	
	Thickness (mm)	1.3	
	Theory Weight (kg/m)	0.365	
	Exposed Surface (m <sup>2</sup> /m)	0.0838	

NO.	Item		Diagram
36	Draw No.		
	Thickness (mm)		
	Theory Weight (kg/m)		
	Exposed Surface (m <sup>2</sup> /m)		
37	Draw No.		
	Thickness (mm)		
	Theory Weight (kg/m)		
	Exposed Surface (m <sup>2</sup> /m)		
38	Draw No.		
	Thickness (mm)		
	Theory Weight (kg/m)		
	Exposed Surface (m <sup>2</sup> /m)		
39	Draw No.		
	Thickness (mm)		
	Theory Weight (kg/m)		
	Exposed Surface (m <sup>2</sup> /m)		
40	Draw No.		
	Thickness (mm)		
	Theory Weight (kg/m)		
	Exposed Surface (m <sup>2</sup> /m)		

Note: In order to avoid the loss caused by mistakes, please communicate and consult with the Technical Department before choosing. The right of final interpretation belongs to the Technical Department.